

12

NEET 2026

Physics_Answer Key

1. A 100-turn closely wound circular coil of radius 5 cm has a magnetic field of 3.14×10^{-3} T at its centre. The current flowing through the coil, and the magnitude of the magnetic moment of this coil are, respectively: (Take $\mu_0 = 4\pi \times 10^{-7}$ Tm/A)

- (1) 2.5 A, 2 A m² (2) 2.5 A, 20 A m²
 (3) 2 A, 4 A m² (4) 2A, 10 A m²

2. Match List I with List II:

	List-I		List-II
A.	$E = hv$	I.	de Broglie wavelength
B.	Diffraction and Interference	II.	Particle nature of light
C.	$\lambda = h/p$	III.	Wave nature of light.
D.	Compton effect	IV.	Energy of photon

Choose the correct answer from the options given below:

- (1) A-IV, B-III, C-I, D-II
 (2) A-I, B-IV, C-III, D-II
 (3) A-IV, B-I, C-II, D-III
 (4) A-IV, B-III, C-II, D-I

3. The current I in the circuit shown below is: (All diodes are ideal and identical)

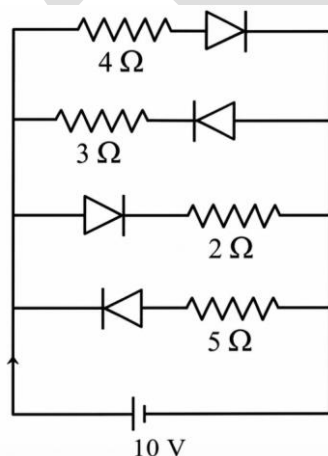

- (1) $\frac{5}{3}$ A (2) $\frac{15}{2}$ A
 (3) $\frac{1}{3}$ A (4) $\frac{5}{9}$ A

4. The speed of light in vacuum is taken as unity. If light takes 6 min 40 s to reach the Earth from the Sun, the distance between the Sun and the Earth in new unit is:

- (1) 3×10^8 (2) 3×10^8
 (3) 400 (4) 500

5. The following plots show variation of velocity (v) with time (t), of a ball thrown vertically upward, and falling back. Which of the following plots is/are correct ?

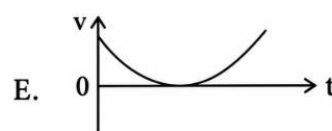
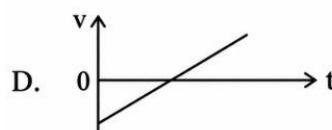
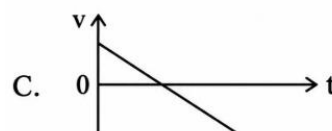
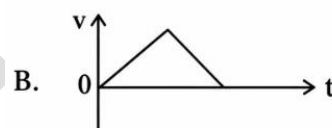
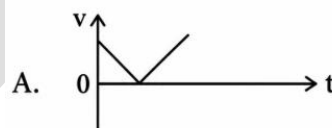

- (1) C only (2) A and E only
 (3) D only (4) B only

6. In a vernier callipers, 20 VSD coincide with 16 MSD (each division of length 1 mm). The least count of the vernier callipers is :
- (1) 0.01 cm (2) 0.1 cm
(3) 0.02 cm (4) 0.2 cm
7. An ac circuit contains a resistance of $1\text{ k}\Omega$, a capacitor of $0.1\text{ }\mu\text{F}$ and an inductor of 1 mH connected in series. The resonance frequency of the circuit is approximately :
- (1) 10.1 kHz (2) 20.7 kHz
(3) 15.9 kHz (4) 13.5 kHz

8. The figure given below shows a long straight solid wire of circular cross-section of radius 'a' carrying steady current I . The current I is uniformly distributed across its cross-section. The plot which correctly represents the variation of magnetic field (B) with distance (r) from the axis of the conductor in the region is:

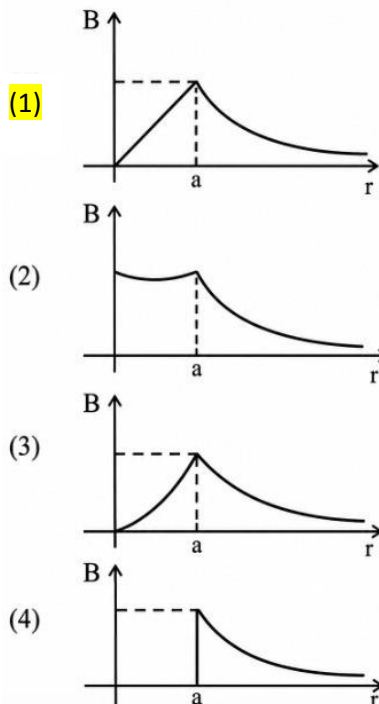
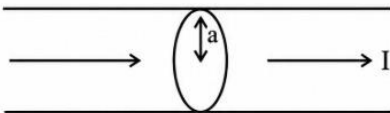

9. A uniform metallic wire having resistance $4\text{ }\Omega$ is bent to form a square loop (ABCD) (see figure). A resistance of $2\text{ }\Omega$ is connected between points B and D and a battery of 2 V is connected across points A and C as shown in the figure. Now the value of current (I) is :

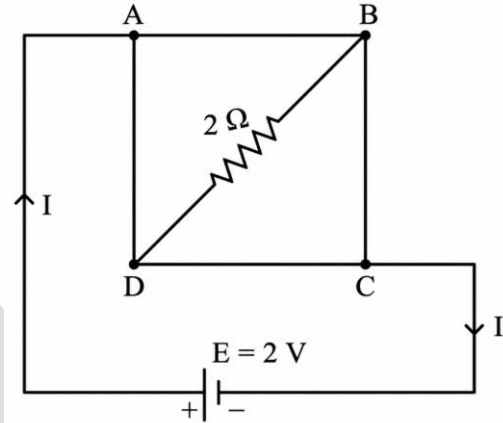

- (1) 2 A** (2) 4 A
 (3) 8 A (4) 4.5 A

10. An unknown nucleus has a nuclear density of $2.29 \times 10^{17}\text{ kg/m}^3$ and mass of $19.926 \times 10^{-27}\text{ kg}$. Its mass number A is approximately : (Take $R_0 = 1.2 \times 10^{-15}\text{ m}$, $4\pi = 12.56$)
- (1) 12** (2) 19
 (3) 20 (4) 16
11. A rectangular wire loop of sides 8 cm and 3 cm with a small cut, is moving out of a region of uniform magnetic field of magnitude 0.3 T directed normal to the plane of the loop. The emf developed across the cut, if the velocity of the loop is 2 cm s^{-1} , in a direction normal to the shorter side of the loop, will be
- (1) $1.8 \times 10^{-4}\text{ volt}$** (2) $1.2 \times 10^{-4}\text{ volt}$
 (3) $1.3 \times 10^{-4}\text{ volt}$ (4) $4.8 \times 10^{-4}\text{ volt}$
12. A galvanometer of resistance $100\text{ }\Omega$ gives full scale deflection for a current of 1 mA . It is converted into an ammeter of range $0 - 10\text{ A}$. The shunt required is :
- (1) $0.01\text{ }\Omega$** (2) $0.10\text{ }\Omega$
 (3) $0.001\text{ }\Omega$ (4) $1.0\text{ }\Omega$

13. In Young's double slit experiment, using monochromatic light of wavelength λ , the intensity of light at a point on the screen where the path difference is λ , is K units. The intensity of light at a point where the path difference is $\frac{\lambda}{3}$ will be :

- (1) $\frac{K}{4}$ (2) K
 (3) $\frac{K}{2}$ (4) 2K

14. The magnitude and direction of the acceleration produced in a body of mass 5 kg when two mutually perpendicular forces 8 N and 6 N act on it, are respectively :

- (1) 2 ms^{-2} ; $\tan^{-1}(3/4)$ with 6 N force
 (2) 2 ms^{-2} ; $\tan^{-1}(4/4)$ with 8 N force
 (3) 2 ms^{-2} ; $\tan^{-1}(3/4)$ with 8 N force
 (4) 20 ms^{-2} ; $\tan^{-1}(4/4)$ with 8 N force

15. Five capacitors of capacitances

$C_1 = C_2 = C_3 = C_4 = 10 \mu\text{F}$ and $C_5 = 2.5 \mu\text{F}$ are connected as shown, along with a battery of 50 V.

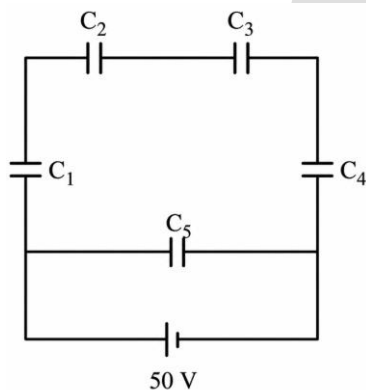

The equivalent capacitance and the charges on each capacitor respectively are :

- (1) $5 \mu\text{F}$, $125 \mu\text{C}$ on all capacitors
 (2) $5 \mu\text{F}$, $250 \mu\text{C}$ on all capacitors
 (3) $4 \mu\text{F}$, $250 \mu\text{C}$ on C_1 to C_4 and $125 \mu\text{C}$ on C_5
 (4) $5 \mu\text{F}$, $125 \mu\text{C}$ on C_1 to C_4 and $25 \mu\text{C}$ on C_5

16. In a metre bridge experiment (see figure), the positions of the cell, E, and galvanometer, G, are shall observe in the interchanged galvanometer :

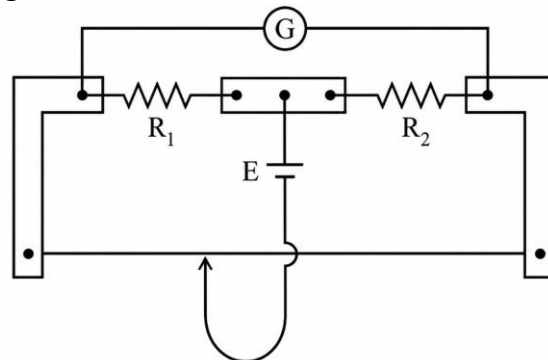

- (1) Only the right-sided deflection
 (2) Only the left-sided deflection
 (3) There will be no deflection irrespective of the position of the jockey
 (4) Both right-sided and left-sided deflection and at balance point, no deflection

17. The power of a crane, which lifts a mass of 1000 kg to a height of 20 m in 10 s is:

- ($g = 9.8 \text{ m/s}^2$)
 (1) 19.6 W (2) 39.2 W
 (3) 39.2 kW (4) 19.6 W

18. Match List I with List II :

	List I		List II
A	Young's Modulus	I	$\frac{\Delta d}{\Delta L} \left(\frac{L}{d} \right)$
B	Compressibility	II	$\frac{FL}{A(\Delta L)}$
C	Bulk Modulus	III	$-\frac{1}{\Delta P} \left(\frac{\Delta V}{V} \right)$
D	Poisson's Ratio	IV	$-P \left(\frac{V}{\Delta V} \right)$

Choose the correct answer from the options given below :

- (1) A-I, B-IV, C-III, D-II
 (2) A-IV, B-I, C-II, D-III
 (3) A-III, B-II, C-I, D-IV
 (4) A-II, B-III, C-IV, D-I

19. In a concave lens, a ray of light emanating from the object parallel to the principal axis of the lens, after refraction :
- (1) emerges parallel to the principal axis.
 - (2) appears to diverge from the first principal focus.
 - (3) passes through $2F$, which is the radius of curvature of the lens.
 - (4) passes through the second principal focus.

20. A thin wire of length 'L' and linear mass density 'm' is bent into a circular ring (in x-y plane) with centre 'C' as shown in figure. The moment of inertia of the ring about an axis yy' will be :

(1) $\frac{3mL^3}{8\pi^2}$

(2) $\frac{3mL^3}{8\pi}$

(3) $\frac{3mL^2}{8\pi^2}$

(4) $\frac{3mL^2}{8\pi}$

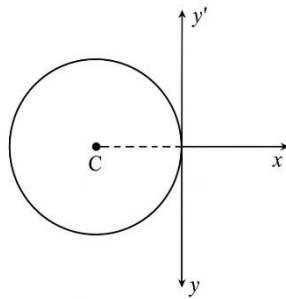

21. Each side of a metallic cube of mass 5.580 kg is measured to-be 9.0 cm. Keeping the significant figures in view, the density of the material of the cube can be best expressed as $X \times 10^3 \text{ kg m}^{-3}$, where the value of X is :
- (1) 7.654
 - (2) 7.7
 - (3) 7.65
 - (4) 7.6

22. For a travelling harmonic wave $y(x, t) = 2.0 \cos 2\pi(10 t - 0.0080 x + 0.35)$, where x and y are in em and t in s. The phase difference between oscillatory motion of two points separated by a distance of 0.5 m is :
- (1) $8 \pi \text{ rad}$
 - (2) $0.08 \pi \text{ rad}$
 - (3) $0.008 \pi \text{ rad}$
 - (4) $0.8 \pi \text{ rad}$

23. A ray of monochromatic light is passing through an equilateral prism (ABC) as shown in the figure. The refracted ray (QR) is parallel to its base (BC) and the angle of incidence (i) is 50° . Then the angle of deviation (δ) is :

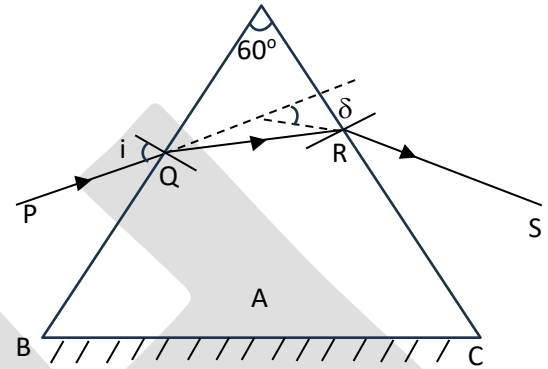

- (1) 40°
- (2) 45°
- (3) 55°
- (4) 35°

24. In the circuit shown below, the voltage appearing across the diode D will be of the form :

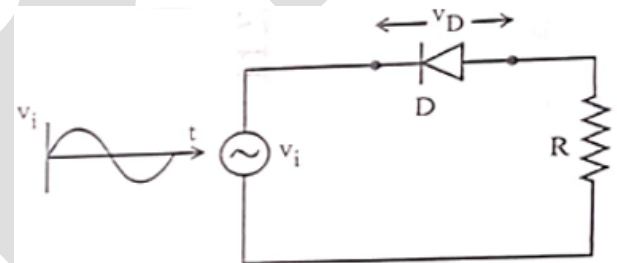

- (1)
- (2)
- (3)
- (4)

(2)

25. For a simple pendulum, having time period T , the variation of kinetic energy (K.E.) with time (t) is represented by :

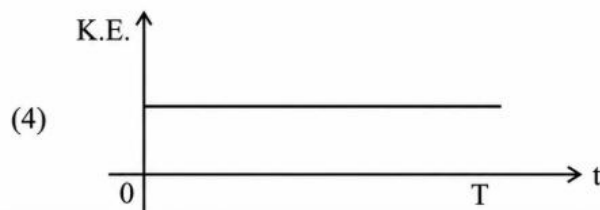
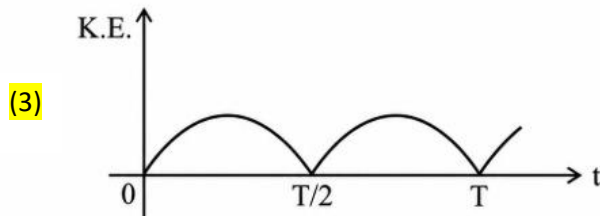
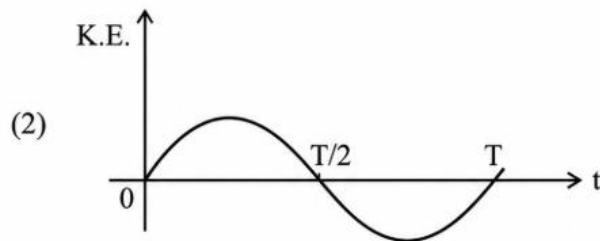
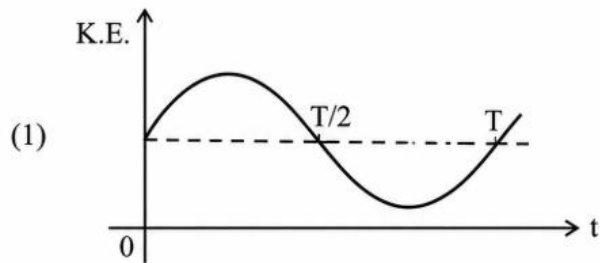

26. A resistor is connected to a battery of 12 V emf and internal resistance 2Ω . If the current in the circuit is 0.6 A, the terminal voltage of the battery is :

- (1) 10 V (2) 10.8 V
(3) 12 V (4) 1.2 V

27. The amount of work done to raise a mass ' m ' from the surface of the Earth to a height equal to the radius of the Earth ' R ', will be :

- (1) $2 mg R$ (2) $mg R$
(3) $mg \frac{R}{4}$ (4) $mg \frac{R}{2}$

28. An electric heater supplies heat to a system at a rate of 100 W. If the system performs work at a rate of 75 J/s, then the rate at which internal energy increases will be :

- (1) 125 W (2) 100 W
(3) 25 W (4) 75 W

29. A room heater is rated 400 W, 220 V. If the supply voltage drops to 200 V, what will be the power consumed (approximately) ?

- (1) 121 W (2) 331 W
(4) 400 W (3) 200 W

30. When a ruler falls vertically, 5 different persons catch it with different reaction times. ($g = 9.8 \text{ m s}^{-2}$)

- A. Person A has reaction time of 0.20 s.
B. Person B has reaction time of 0.22 s.
C. Person C has reaction time of 0.18 s.
D. Person D has reaction time of 0.19 s.
E. Person E has reaction time of 0.21 s.

What is the correct order of the distance travelled by the ruler for each person?

- (1) $C > D > A > B > E$
(2) $C > D > A > E > B$
(3) $B > E > A > C > D$
(4) $B > E > A > D > C$

31. Consider two uncharged capacitors of equal capacitance 200 pF. One of them is charged by a 100 V supply and disconnected. Now this capacitor is connected to the uncharged capacitor. The amount of electrostatic energy lost in the process is :

- (1) $1.0 \times 10^{-6} \text{ J}$ (2) $0.5 \times 10^{-6} \text{ J}$
(3) 0.5 J (4) 1.0 J

32. Savitha, a XI standard student, while conducting an experiment to determine the effective length of a simple pendulum L , notes down the data of time taken to complete 30 oscillations as 60 s and hence calculates the length of the simple pendulum as :
(Take $\pi^2 = 9.8$, and $g = 9.8 \text{ m/s}^2$)
- (1) 2 m (2) 0.75 m
(3) 1.5 m (4) 1 m
33. The peak value-of an alternating current is 5 A and frequency is 60 Hz. How long will the current, starting from zero, take to reach the peak value?
- (1) $\frac{1}{240}$ S (2) $\frac{1}{30}$ S
(3) $\frac{1}{120}$ S (4) $\frac{1}{60}$ S
34. In interference-and diffraction, the light energy is redistributed. If it reduces in one region, producing a dark fringe it increases in another region, producing a bright fringe.
- A. As there is no gain or loss of energy, these phenomena are consistent with the principle of conservation of energy.
B. Diffraction and interference are characteristics exhibited only by light waves.
- Choose the correct answer from the options given below :
- (1) A is true, but B is false
(2) A is true and B is also true
(3) A is false, but B is true
(4) Both A and B are false
35. A box of mass 15 kg is kept on the floor of a stationary trolley. The coefficient of static friction between the box and the trolley is 0.12. Keeping the box in stationary state over the trolley, the maximum acceleration with which the trolley can be moved horizontally in m/s^2 is : ($g = 10 \text{ m/s}^2$)
- (1) 1.5 (2) 1.8
(3) 2.1 (4) 1.2
36. The sum of kinetic energy and potential energy of a simple pendulum bob is 0.02 joule. The speed of the simple pendulum bob at equilibrium position is approximately :
(Consider mass of the bob = 20 g)
- (1) 1.41 m/s (2) 14.1 m/s
(3) 0.2 m/s (4) 2.0 m/s
37. Four statements are given (A is mass number):
- A. The volume of a nucleus is proportional to $A^{1/3}$
B. The volume of a Nucleus is proportional to A.
C. The difference in mass of an atom and its nucleus is called the mass defect.
D. The difference in mass of a nucleus and its constituents is called the mass defect.
- Choose the correct answer from the options given below :
- (1) B and D are true, but A and C are false
(2) A and D are true, but B and C are false
(3) A and C are true, but B and D are false
(4) B and C are true, but A and D are false
38. The angular speed of a flywheel is increased from 600 rpm to 1200 rpm in 10 s. The number of revolutions completed by the flywheel during this time is :
- (1) 600 (2) 900
(3) 300 (4) 150

39. A submarine is designed to withstand an absolute pressure of 100 atm. How deep can it go below the water surface ?

(Consider the density of water = 1000 kg m^{-3} , $1 \text{ atm} = 1 \times 10^5 \text{ Pa}$ and $g = 10 \text{ m/s}^2$)

- (1) 9900 m (2) 99 m
(3) 9000 m (4) 990 m

40. Match List I with List II:

	List I (Electromagnetic wave)		List II (Production)
A	Microwave	I	Electrons in atoms emit light when they move from a higher energy level to a lower energy level
B	Visible light	II	Radioactive decay of nucleus
C	Gamma rays	III	Vibration of atoms and molecules
D	Infra-red rays	IV	Klystron valve or magnetron valve

Choose the correct answer from the options given below :

- (1) A-III, B-I, C-II, D-IV
(2) A-III, B-IV, C-I, D-II
(3) A-IV, B-III C-II, D-I
(4) A-IV, B-I, C-II, D-III

41. Which of the following statements are correct ?

- A. Inside a conductor, the electrostatic field is zero.
B. Electric field at the surface of a charged conductor does not depend on its surface charge density.
C. The interior of a charged conductor can have no excess charge in the static situation.

D. At the surface of a charged conductor, the electrostatic field must be normal to the surface at every point.

E. The electrostatic potential is zero everywhere inside a charged conductor.

Choose the correct answer from the options given below :

- (1) C, D and E only (2) A, B and D only
(3) A, C and D only (4) A, C and E only

42. For a metal of work function 6.6 eV, which of the following wavelengths of incident radiation does not give rise to the photoelectric effect ?

(Take Planck's constant as $6.6 \times 10^{-34} \text{ J s}$)

- (1) 200 nm (2) 150 nm
(3) 100 nm (4) 50 nm

43. In the first excited state of hydrogen atom, the energy of its electron is - 3.4 eV. The radial distance of the electron from the hydrogen nucleus in this case is approximately :

(Take $1 \text{ eV} = 1.6 \times 10^{-19} \text{ J}$, $e = 1.6 \times 10^{-19} \text{ C}$ and

$$\frac{1}{4\pi\epsilon_0} = 9 \times 10^9 \text{ N m}^2/\text{C}^2$$

- (1) $2.1 \times 10^{-8} \text{ m}$ (2) $2.1 \times 10^{-11} \text{ m}$
(3) $2.1 \times 10^{-9} \text{ m}$ (4) $2.1 \times 10^{-10} \text{ m}$

44. Two statements are given below :
- A. When the forward bias voltage across a p-n junction diode increases above a certain threshold voltage, the diode current increases significantly.
 - B. This current is called reserved saturation current.

Choose the correct answer from the options given below :

- (1) Both Statements A and B are false
 - (2) Statement A is true, but Statement B is false
 - (3) Both Statements A and B are true
 - (4) Statement A is false, but Statement B is true
45. A flask contains argon and chlorine in the ratio of 2 : 1 by mass. The temperature of the mixture is 27°C. The ratio of root mean square speed of the molecules of the two gases

$$\left(\frac{v_{\text{rms}}^{\text{Ar}}}{v_{\text{rms}}^{\text{Cl}}} \right) \text{ is :}$$

(Atomic mass of argon = 40.0 u and molecular mass of chlorine = 70.0 u)

- (1) $\frac{\sqrt{7}}{2}$
- (2) $\frac{7}{2}$
- (3) $\frac{7}{4}$
- (4) $\frac{2}{\sqrt{7}}$

NEET 2025

80 घुरंधर

MBBS
सिलेक्शन



NOW @
NAIR
MUMBAI

99.55%ile

AYUSH VISHWAKARMA

556 / 720

GMC
BARAMATI

SHRUTI TIWARI
544/720
99.31%ile

GMC
SOLAPUR

ASHWIKA CHAKKATTIL
536/720
99.09%ile

RGMC
MUMBAI

RIDIMA BHOSLE
536/720
99.09%ile

KJS
SION

TISHA JANGID
529/720
98.87%ile

GMC
MUMBAI

SHRADDHA DUBEY
527/720
98.80%ile

GMC
AKOLA

SHRADDHA YADAV
526/720
98.77%ile

GMC
ALIBAUG

MAHEK TIWARI
523/720
98.65%ile

SVNGMC
YAVATMAL

KHUSHI NIHALANI
522/720
98.61%ile

GMC
DHULE

TUSHAR JANGID
520/720
98.54%ile

GMC
AMRAVATI

POOJA SINGH
517/720
98.42%ile

GMC
NANDURBAR

KHUSHI MISHRA
515/720
98.33%ile

GMC
NANDURBAR

SHRUTI MAURYA
511/720
98.16%ile

GMC
GONDIA

ABDUL CHOUDHARY
511/720
98.16%ile

JNMC
BELGAUM

SUBHAAN PATANWALA
507/720
97.97%ile

GMC
BHANDARA

MONAL SINGH
506/720
97.92%ile

GMC
GADCHIROLI

ADWITA MISHRA
505/720
97.87%ile

GMC
GADCHIROLI

DHANRAJ MISHRA
504/720
97.82%ile

KMC
GADCHIROLI

AKSHITA TRIPATHI
504/720
97.82%ile

NEET 2025



NOW @
LTMC
MUMBAI
99.48%ile

MD. ARQAM ANSARI

552 /720



NOW @
GT & CAMA
MUMBAI
99.46%ile

TIRTHA NAIR

551 /720



GMC
ALIBAUG

AMEERA KAZI

533/720

99.00%ile



GMC
NANDED

PRATHVI SALIAN

532/720

98.97%ile



RGMC
MUMBAI

NEHA SHARMA

530/720

98.90%ile



RGMC
MUMBAI

HARKRISH JOSHI

520/720

98.54%ile



GMC
AMRAVATI

MANISH KUMAVAT

520/720

98.54%ile



GMC
NANDURBAR

PRINCE SOLANKI

520/720

98.54%ile



GMC
BULDHANA

HRISHIKESH DUBE

511/720

98.16%ile



GMC
SINDHURG

ALKA SINGH

509/720

98.06%ile



GMC
BHANDARA

VAIBHAV DAMANI

509/720

98.06%ile



VPMC
NASHIK

KOMAL SINGH

503/720

97.77%ile



KNMC
PUNE

VRUSHTI VAGHASIA

502/720

97.72%ile



IIMSR
JALNA

ALISHA SYED

502/720

97.72%ile

Name

Darshan Gharat
Saniya Shaikh
Saher Farooque
Yugank Utta
Dilip Modi
Ambika Chaurasiya
Riya Thacker
Anu Chhawchharia
Misba Khan
Taniya Raina
Ayush Mishra
Viraag Kothari
Khushi Bajaj
Piyush Jain
Srithaja Yalaka
Vaishnavi Pal
Harshit Yadav
Nehali Kashid
Shreyash Wagharalkar
Ashraful Khan
Aditya Gupta
Kadambari Belekar
Ananya Tandle
Kalash Mishra
Saachi Jadhav
Khushi Chaurasia
AadityaYadav
Heva Raut
Tanishk Rai
Vidya Chhetiar
Amaan Patanwala
Zoya Ali Sayed
Harshika Dalvi
Akshita Shetty
Preeti Chauhan
Vaishnavi Singh
Hiya Tibrewala
Hiral Patel
Vaishnavi Agarwal
Naina Sahu
Archie Sharma
Shreeram Dubey
Palavi Kadam
Anuj Singh
Krishna Dubey
Sneha Dubey
Farhan Shaikh

College

KNMC, Pune
KNMC, Pune
MIME, Talegaon
ACPM, Dhule
SMBT, Nashik
PDMC, Amravati
SMBT, Nashik
SMBT, Nashik
IIMSR, Jalna
VVPFMC, Ahilyanagar
ACPM, Dhule
ACPM, Dhule
SMBT, Nashik
SMBT, Nashik
ACPM, Dhule
ACPM, Dhule
PIMC, Sangli
NYTMC, Karjat
SNKMC, Kopergaon
SSPM, Sindhudurg
VMC, Palghar
GT & CAMA, Mumbai
NYTMC, Karjat
MIMS, Lucknow
GMC, Ratnagiri
SGMC, Gorakhpur
SMBT, Igatpuri
GMC, Alibaug
HIMC, Varanasi
ASMC, AP
JNMC, Belgaum
MGMC, Navi Mumbai
MGM, Panvel
AJIMC, Mangalore
SKSMC, Mathura
RMC, UP
PIMC, Lucknow
Naraina, Kanpur
MGMC, Navi Mumbai
PMC, Jharkhand
DY Patil, Navi Mumbai
SRNMC, Allahabad
BVMC, Pune
SCMC, Bihar
CMC, Lucknow
TSMC, Lucknow
CMC, Lucknow

सपने नहीं हकीकत बुनते है,
तमी तो SCIENCE वाले **TSPH** चुनते है ।

Challenge Your Limits!

BHAYANDAR BRANCH

1st Floor, Ashoka Shopping Centre,
Navghar Road, Near Railway Station,
Bhayandar (E),

☎ 8652 375 375

MIRA ROAD BRANCH

1st Floor, D/232, Shanti Shopping Centre,
Near Railway Station,
Mira Road (E)

☎ 8652 373 373